

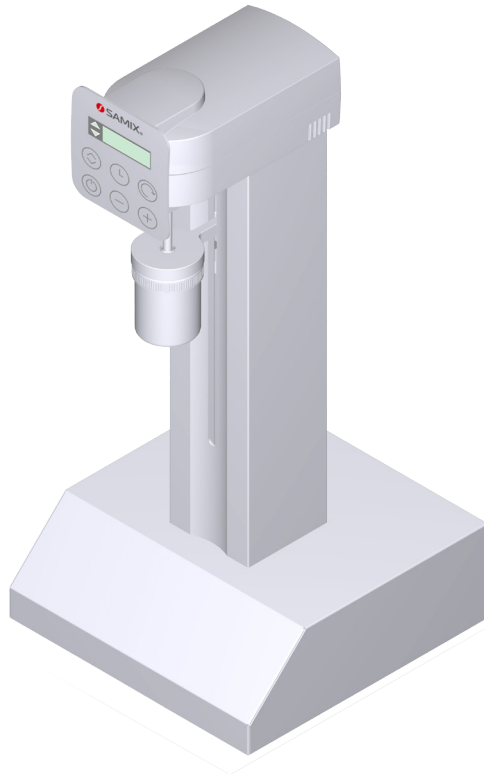

SAMIX® ES500



Original Instruction Manual

© 2017 SAMIX GmbH

This instruction manual is protected by copyright laws. Disclosure, as well as reproduction of this document, utilization and communication of its content, are prohibited, unless explicit written consent has been granted by SAMIX GmbH. Offenders will be held liable for the payment of damages. All rights reserved in the event of the grant of a patent, utility model or design.

Inhaltsverzeichnis

1	Basic comments	5
1.1	General specifications	5
1.2	Intended use	5
1.3	Foreseeable misuse	5
1.4	Limits of operating range	5
1.5	Manufacturer's warranty	6
1.6	Scope of delivery	6
1.7	Manufacturer's Customer Service	6
2	Safety	7
2.1	Structure of safety notices	7
2.2	General safety notices	8
2.3	Safety devices	9
3	Technical description	10
3.1	Technical data	10
3.2	Product range	10
3.2.1	Mixing blade	11
3.2.2	Jars	13
3.2.3	Assignment of mixing blades to the jars	15
4	Transportation, packaging and storage	17
4.1	Transportation	17
4.2	Packaging	17
4.3	Storage	17

5	Initial operation	18
5.1	Site selection	18
5.2	Initial operation	19
5.3	Function check	19
6	Operation	21
6.1	Control panel and display	21
6.2	Preparation of mixing unit	23
6.3	Preparation of mixing process	25
6.4	Switching on and selecting the operating mode	26
6.5	Mixing process in AUTO operating mode	29
6.5.1	Starting the mixing process	29
6.5.2	Switching off and removing the mixing unit	31
6.6	Mixing process in MANUAL operating mode	32
6.6.1	Starting the mixing process	32
6.6.2	Manual free spin motion	34
6.6.3	Switching off and removing the mixing unit	37
6.7	Final operations	38
7	Maintenance, repair and cleaning	41
7.1	Service and warranties in Germany	41
7.2	Maintenance	42
7.3	Cleaning	43
8	Fault causes/troubleshooting	44
8.1	Instructions in the event of faults	44
8.2	Fault messages	45
8.3	Possible fault sources to avoid	46
9	Waste disposal	48

1 Basic comments

1.1 General specifications

The SAMIX® ES500 is manufactured by SAMIX GmbH, and its safety has been checked by the TÜV Rheinland.

For safe operation, and to avoid personal injuries and material damage,

- the instruction manual must be read carefully and understood,
- the instruction manual must always be available at the mixer and observed.

The current instruction manual describes the structure, operating principle and handling of the SAMIX® ES500 mixer.

1.2 Intended use

The SAMIX® ES500 mixer is solely intended for the manufacture of pharmaceutical and cosmetic products.

1.3 Foreseeable misuse

The following usage is considered foreseeable misuse:

- use of excessively large jars (nominal volume: 1000 ml)
- operation of mixing blades without jar
- implementing the mixing process in MANUAL operating mode, whereby the shaft of the mixing blade is not properly engaged in the bayonet mount of the device
- no coaxial guidance of the jar to the device

1.4 Limits of operating range

SAMIX® devices are designed for operation in a normal room atmosphere. An ambient temperature of 15 - 30 °C and relative air humidity below 80% are recommended.

1.5 Manufacturer's warranty

As a customer, you also receive explicit warranty rights from the manufacturer with the enclosed manufacturer's warranty. Please note the details in the enclosed documentation.

1.6 Scope of delivery

Check your purchase for completeness immediately upon receipt. The scope of delivery includes:

- SAMIX® ES500
- Accessories
- Instruction manual

When checking for completeness, please also observe the information in the enclosed document "Installation Qualification (IQ)".

If there are parts missing or damaged, please contact the manufacturer.

1.7 Manufacturer's Customer Service

SAMIX GmbH
Am Köhlersgehäu 50
98544 Zella Mehlis
Germany

www.samix.com
info@samix.com

Tel.: +49 3682 455 0
Fax: +49 3682 455 200

2 Safety

2.1 Structure of safety notices

The safety notices in this document are marked with safety symbols and designed in accordance with the SAFE principle. They contain information on the type and source of danger, possible consequences, as well as measures to prevent the danger.



DANGER

Warns against an accident which occurs when the instructions are not followed. The accident leads to serious, possibly life-threatening, injuries or death, for e.g. by touching high-voltage electrical units.



WARNING

Warns against an accident which occurs when the instructions are not followed. The accident leads to serious, possibly life-threatening, injuries or death, for e.g. by touching high-voltage electrical units.



CAUTION

Warns against an accident which occurs when the instructions are not followed. The accident may cause minor injuries, for e.g. burns, wounds, incisions or bruises.



ATTENTION

Warns against possible material damage.



NOTICE

Important general information.



NOTICE

Important information on environment protection.

2.2 General safety notices



WARNING

Risk of injury from rotating parts and during the automatic lifting function!

Do not touch rotating parts! Keep long hair, ties, scarves, etc., away from rotating parts and the lifting mechanism.

Only use mixing blades with the SAMIX® ES500 in jars which have been firmly screwed in.

In the event of an emergency, immediately switch off the device using the power switch or disconnect the connector!



WARNING

Risk of injury from handling hazardous materials!

Do not operate SAMIX® devices in a dangerous atmosphere. Observe the relevant safety regulations when handling hazardous substances (for e.g. combustible liquids such as alcohol)!



HINWEIS

If the device has been disconnected from the mains while performing a mixing program, the mixing process has to be repeated. The mixing program is not continued after the interruption.



HINWEIS

If the mixing process was mechanically interrupted, the device switches off due to an overload and has to be switched off for cooling using the power switch. After cooling the mixing process has to be repeated.

Also observe the following information in order to avoid material damage:

- Only connect SAMIX® devices to appropriately grounded sockets with 230 V or with country-specific nominal voltage which have been installed in accordance with DIN VDE 0100.
- Acclimatize the SAMIX® ES500 to room temperature for roughly 30 minutes before the initial operation or after a prolonged storage time in cold rooms.
- SAMIX® devices are designed for operation in a normal room atmosphere. Only operate the SAMIX® devices at an ambient temperature of 15 - 30 °C and relative humidity below 80%.
- Only operate the mixing blade in jars which have been fastened with screws.
- Do not immerse SAMIX® devices in water.
- Only allow skilled electricians to install or remove electrical parts.



NOTICE

If SAMIX® devices are not used in accordance with this instruction manual or with products not supplied or recommended by the manufacturer, the warranty becomes null and void and the intended protection may be affected.

2.3 Safety devices

For substances with high viscosity, a cooling time of 30 minutes is required after a mixing period of 5 minutes at maximum speed (2100 rpm) in order to not overload the SAMIX® ES500. The possible working time of the device increases if substances with a lower viscosity or lower quantities are used.



NOTICE

In the event of an overload, a thermal safety element shuts down the SAMIX® ES500.

3 Technical description

3.1 Technical data

Name	Value
Mains connection	230 V/50 Hz; 120 V/60 Hz
Overall power consumption	270 W
Power consumption (mixing engine)	220 W
Power consumption (lifting engine)	50 W
Type of operation	KB 5 30 minute interval after 5 minutes of mixing
Protection class	I
Protection type	IP 21
Adjusting knob	electronically controlled in 10 stages (650 - 2100 rpm)
Time setting	infinitely variable (electronic)
SAMIX® jar size	15 - 500 ml (nominal volume)
Weight	9.5 kg
Dimensions (L x B x H in mm)	300 x 300 x 650
Conformity sign	CE sign

Tab. 1: Technical data

3.2 Product range

The SAMIX® product range includes:

- Standard mixing blade (SMB)
- Disposable blade (DSP)
- Jars
- Dosing aids (vario nozzles, applicators and ExactDose)
- Removal or filling aids (spindle, coupling and the SAMIX® jar pump with a nominal volume from 300 ml)

All SAMIX® products are compatible with each other.

3.2.1 Mixing blade

Due to the even upward and downward movement of the SAMIX® jar (see section „3.2.2 Jars“), a consistent mix of the substances is achieved with use of the mixing blade (SMB or DSP).



NOTICE

Do not use mixing blades which are bent or defective in any other way.

Wetting the SAMIX® jar and the SAMIX® mixing blade with an ointment base protects the plastic parts against abrasion and wear. Discoloration of the mixing blade is generally harmless.



NOTICE

Mixing blades cannot be placed in the microwave.

Cleaning the mixing blade



ATTENTION

Risk of material damage!

SAMIX® devices and products cannot be treated with sharp objects or abrasive cleaning agents.

1. Clean the mixing blade with cellulose.
2. Wash the mixing blade under hot water or in the dishwasher.

Standard mixing blade (SMB)

Standard mixing blades (see Fig. 1) are adjusted to the respective jar (see section „3.2.3 Assignment of mixing blades to the jars“).

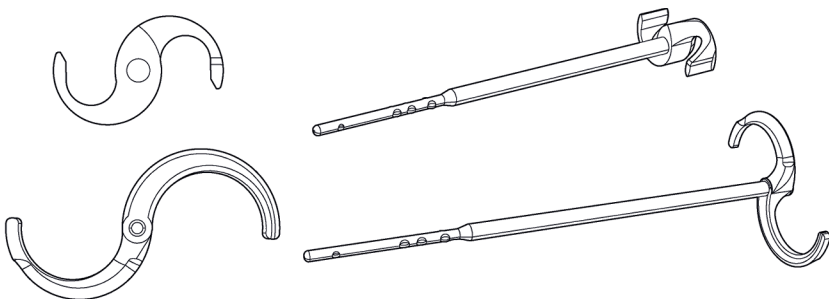

Fig. 1: Standard mixing blade (SMB)

Before use, check whether

- the mixing blade is the right length and size
- the mixing blade is clean. If necessary, disinfect the mixing blade (for e.g. with 70% isopropyl alcohol).

Disposable blade (DSP)



NOTICE

In the case of substances with strong colors, it is recommended to use the disposable blade.

Disposable blades (see Fig. 2) are adjusted to the respective jar (see section „3.2.3 Assignment of mixing blades to the jars“).

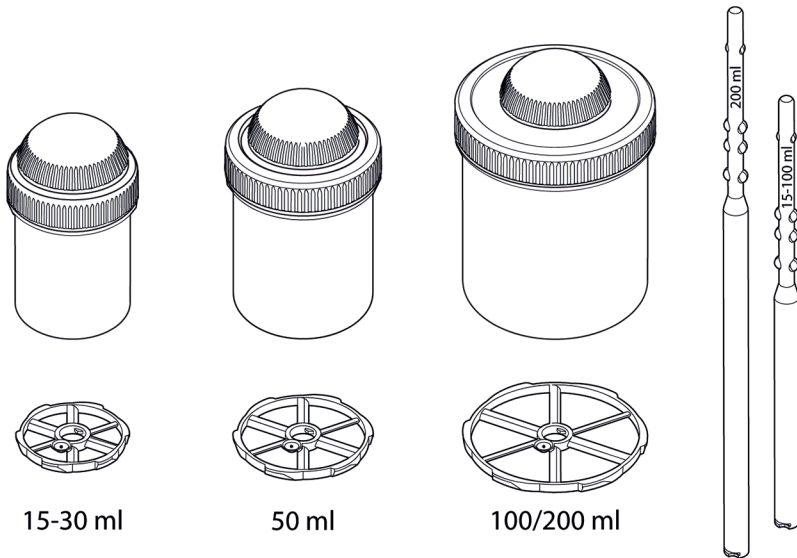

Fig. 2: Disposable blade (DSP): Overview

The DSP are supplied in dispensers, which allow individual removal with the shaft. Before the mixing process, apply gentle pressure to the mixing blade of the DSP and turn it in an anticlockwise direction with the shaft of the DSP.



NOTICE

Ensure correct orientation in accordance with Fig. 3. The injection point faces upwards, the slanted outer contours face downwards.

After the mixing process, the shaft of the DSP is disconnected from the mixing blade of the DSP by turning in a clockwise direction (see Fig. 3).

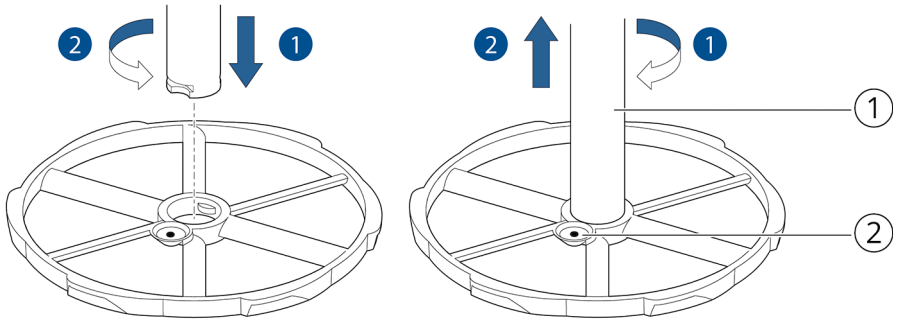

Fig. 3: Disposable blade (DSP): Assembly and disassembly

1 DSP shaft

2 Injection point



NOTICE

The cleaning is restricted to the shaft of the DSP.

3.2.2 Jars

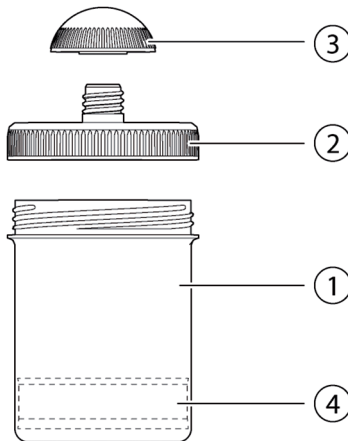

Fig. 4: Jar

1 Jar housing

3 Jar cap

2 Jar lid

4 Jar base (movable)

Jars (see Fig. 4) have a movable base and can be mixing and dispensing containers. The jar lid seals the jar without a loss of the active ingredients. As mixing containers, jars guarantee manufacture in the air-reduced mixing chamber free of evaporation and contamination. As dispensing containers, jars correspond to the quality assurance guideline of the German Chamber of Pharmacists. The small dispenser opening without an environmental contamination area guarantees the minimization of negative quality effects (for e.g. by finger germs) as required by § 13 ApBetrO for the dispensing of the ointment or cream from the jars.



NOTICE

A jar is a disposable container and cannot be rinsed before use. Otherwise, the inspected sterility is jeopardized.

SAMIX® jars are supplied in the following sizes:

Nominal volume (filling volume)	Nominal volume (filling volume)	Nominal volume (filling volume)
15 (28) ml	50 (70) ml	300 (390) ml
20 (33) ml	100 (140) ml	500 (600) ml
30 (42) ml	200 (280) ml	1000 (1250) ml

Tab. 2: Jar sizes



NOTICE

Only use jars with a nominal volume up to 500 ml for the SAMIX® ES500.

Jars are supplied sealed in a film sleeve.



NOTICE

Also after the beginning of the film sleeve it is recommended to store non-used jars in the film sleeve to protect against possible dust contamination.



NOTICE

SAMIX® jars are subject to regular checks in accordance with ZL packaging regulation DK II/94. An analysis certificate is issued after batch-defined inspections. The documentation of primary packaging material in the pharmacy includes the retention of the manufacturer's inspection certificate (analysis certificate) after a visual incoming test. This is adhered to the film sleeve containing the jars. It can be removed from the film sleeve and kept with the documentation.



NOTICE

SAMIX® jars are designed for one-off use. Multiple usage as a mixing container is not permitted for hygienic and technical reasons.

3.2.3 Assignment of mixing blades to the jars



NOTICE

An incorrect assignment of the mixing blades to the jars can trigger fault messages or mean that the incorrectly prepared mixing unit cannot be screwed into the oscillation arm.

Standard mixing blade (SMB)

Ensure correct assignment of the mixing blades to the corresponding jars. The SMB for jars with a nominal volume of 100, 200, 300 and 500 ml have the same diameter of the mixing blade, but differ in the length of the shaft (see Fig. 5).

Disposable blade (DSP)

There are also different shaft lengths for DSP. The two available DSP shafts are marked for the use of jars with a nominal volume between 15 and 100 ml or 200 ml, and must be combined with the respective DSP. For jars with a nominal volume of 100 and 200 ml, the same DSP are used but with different shafts.



NOTICE

Also observe the operating instructions enclosed with the mixing blade shafts.

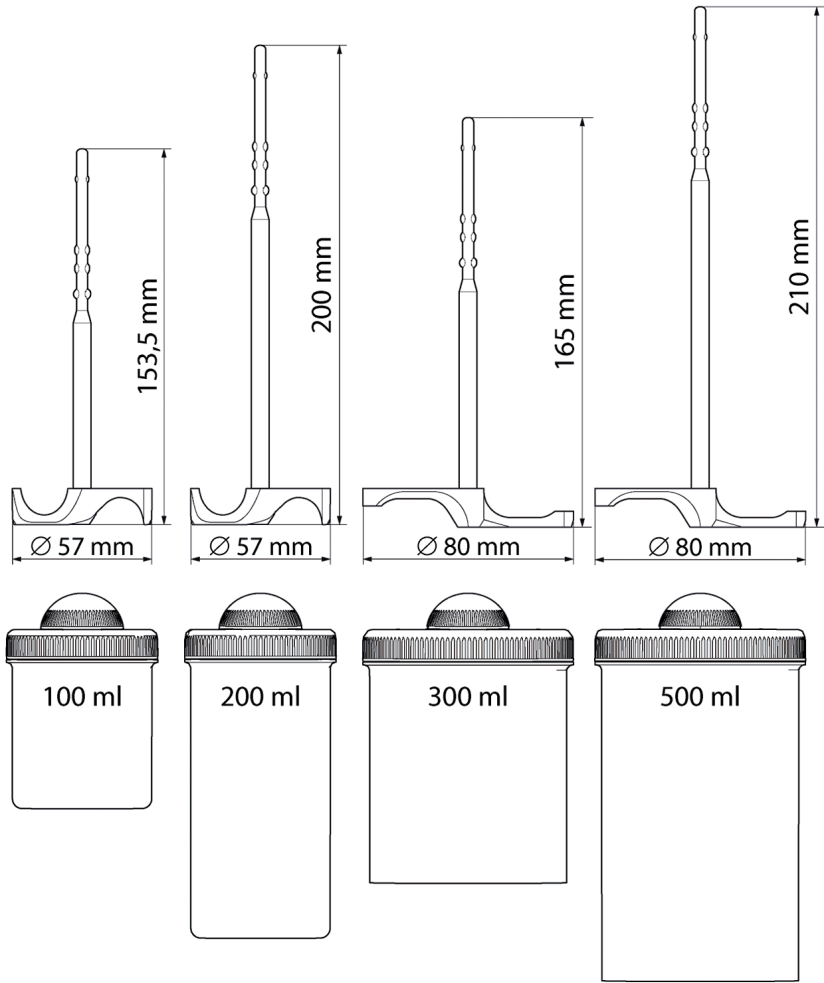

Fig. 5: Assignment of the standard mixing blade with different shaft lengths

4 Transportation, packaging and storage

4.1 Transportation



CAUTION

Risk of crushing when lifting and transporting the SAMIX® ES500.

It is recommended to call on the assistance of a second person when lifting and transporting the SAMIX® ES500.

The SAMIX® ES500 is sent in a cardboard box.

4.2 Packaging

Store the packaging (cardboard box and inserts) in case you have to send in the SAMIX® ES500.

4.3 Storage

Protect the SAMIX® ES500 against direct sunlight, extreme humidity and huge temperature fluctuations.

Store the SAMIX® ES500 at an ambient temperature between +15 °C and +30 °C and relative humidity below 80%.

5 Initial operation



CAUTION

Risk of crushing when lifting and transporting the SAMIX® ES500.

It is recommended to call on the assistance of a second person when lifting and transporting the SAMIX® ES500.

5.1 Site selection

Choose a suitable location for the SAMIX® ES500. Observe the following information:

- Position the SAMIX® ES500 on steady, even ground.
- Ensure that there is enough space for the operation of the SAMIX® ES500. The power switch and mains connector must be easily accessible.
- SAMIX® devices satisfy the safety standards for laboratory equipment. Choose a location for the device which prevents handling by unauthorized people.
- Ensure good ventilation in the area of the SAMIX® ES500.
- Choose a location away from the direct air flow of air conditioning systems, heaters, open windows or fans.
- Protect the SAMIX® ES500 against direct sunlight, extreme humidity (max. 80%) and high temperature fluctuations. An ambient temperature between +15 °C and +30 °C is recommended.
- Keep the SAMIX® ES500 clean, dry and dust-free.



NOTICE

When checking for suitable erection conditions, please also observe the information in the enclosed document "Installation Qualification (IQ)".

5.2 Initial operation



ATTENTION

Risk of material damage from condensation in the device!

Acclimatize the SAMIX® ES500 to room temperature for roughly 30 minutes before the initial operation, in the case of low temperatures or after a prolonged storage time in cold rooms.

1. Check the supply connections. Observe the information in the enclosed document "Installation Qualification (IQ)".



CAUTION

Risk of injury from unexpected startup of the device!

Before connecting the SAMIX® ES500, check that the power switch at the pedestal is switched off on the back of the device.

2. Connect the power cord of the SAMIX® ES500 to the socket.
The device is now ready for operation.



NOTICE

In the event of an emergency, the SAMIX® ES500 can be shut down by switching off the device with the power switch or disconnecting the power cord from the socket.

5.3 Function check

Perform a function check in accordance with the details under "Function check or initial operation" in the enclosed document "Installation Qualification (IQ)".



NOTICE

The operation of the SAMIX® ES500 using the control panel and display is described in detail in chapter „6 Operation“.

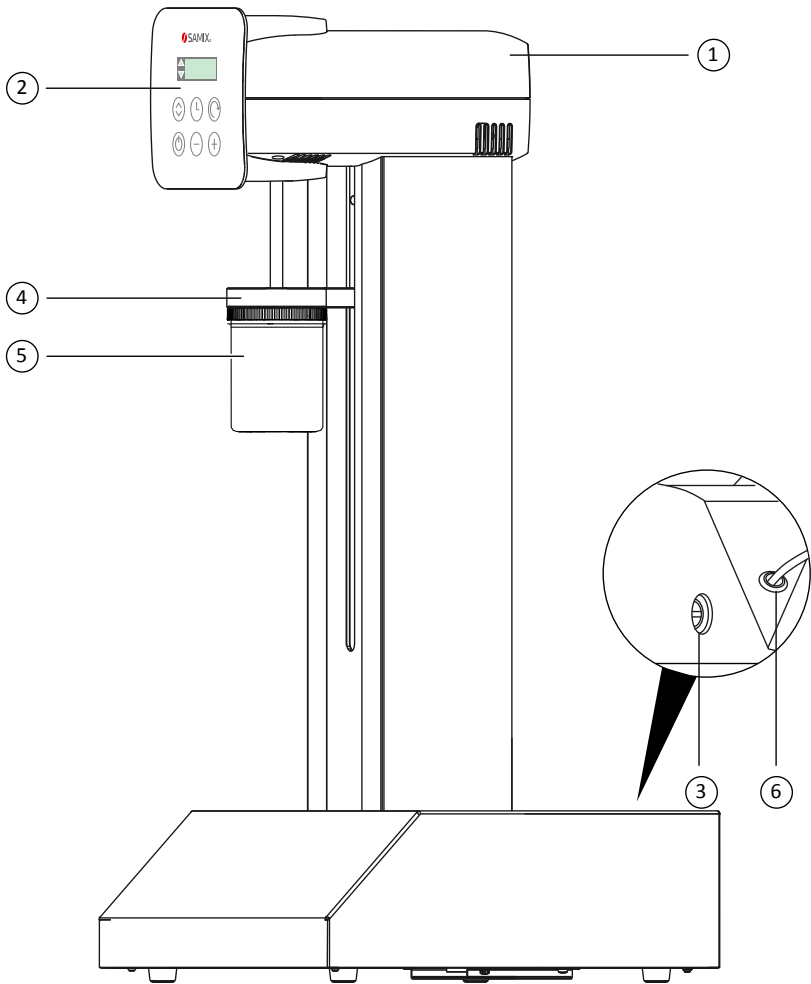

Fig. 6: SAMIX® ES500

- | | | | |
|---|---------------------------|---|-----------------|
| 1 | Drive head | 4 | Oscillation arm |
| 2 | Control panel and display | 5 | Mixing unit |
| 3 | Power switch | 6 | Power cord |

6 Operation

6.1 Control panel and display

For manual control of the SAMIX® ES500, there is a display and control panel on the front of the device with six buttons "AUTO/MANUAL", "Time", "Speed", "-", "+" and "Start/Stop" (see Fig. 7).

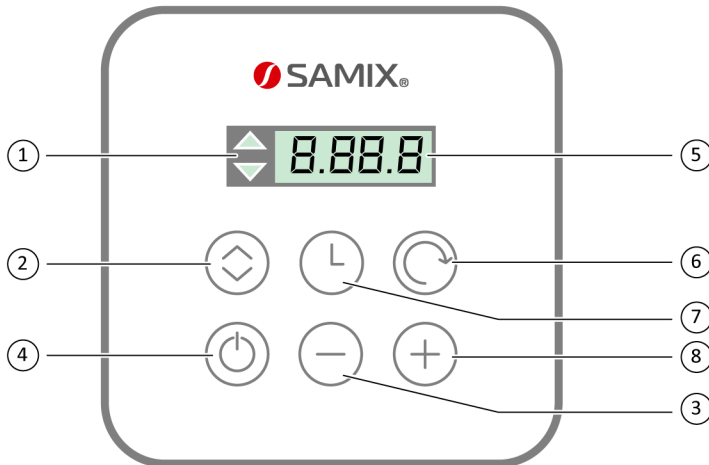

Fig. 7: Control panel and display

- | | | | |
|---|---------------------------------------|---|----------------|
| 1 | Display of the operating mode (light) | 5 | Display |
| 2 | "AUTO/MANUAL" button | 6 | "Speed" button |
| 3 | "-" button | 7 | "Time" button |
| 4 | "Start/Stop" button | 8 | "+" button |

The menu guidance using the display is effected using the buttons on the control panel.

Button	Function
AUTO/MANUAL	Switch between the operating modes AUTO (automatic lifting) and MANUAL (manual lifting)
Time	Switch to the mode to select the mixing time
Speed	Switch to the mode to select the speed setting
+ / -	Setting mixing time or speed setting
Start/Stop	Start or cancel the mixing process

Tab. 3: Functions of buttons on control panel



NOTICE

Further operation of the SAMIX® ES500 using the control panel and display for the mixing process is described in the sections „6.4 Switching on and selecting the operating mode“, „6.5 Mixing process in AUTO operating mode“ and „6.6 Mixing process in MANUAL operating mode“.

6.2 Preparation of mixing unit

A SAMIX® mixing unit consists of

- jar,
- mixing blade,
- the components to be mixed.

Prepare the mixing unit for the mixing process as follows:

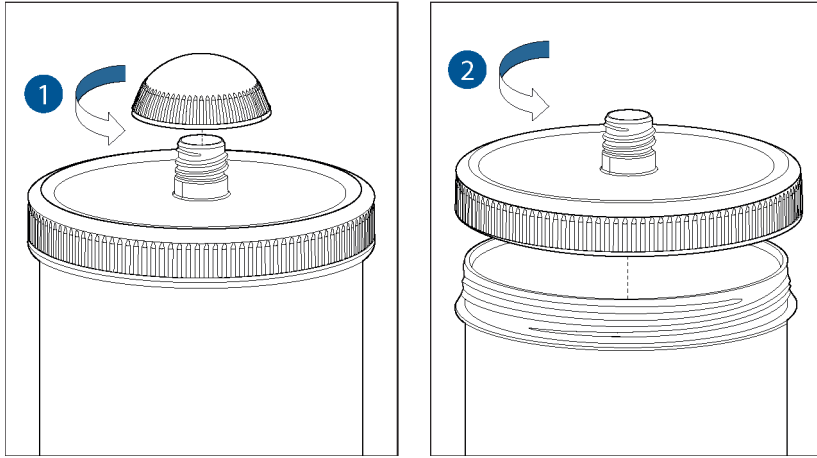

Fig. 8: Unscrew jar cap and jar lid



NOTICE

Observe the correct assignment of the mixing blades to the jars (see section „3.2.3 Assignment of mixing blades to the jars“).



NOTICE

Ensure you do not break the sealing lip of the jar lid opening with the noses of the mixing blade shaft when inserting the mixing blade in the jar lid. Otherwise, ointment elements (mainly liquid) may draw up at the shaft of the mixing blade during the mixing process.

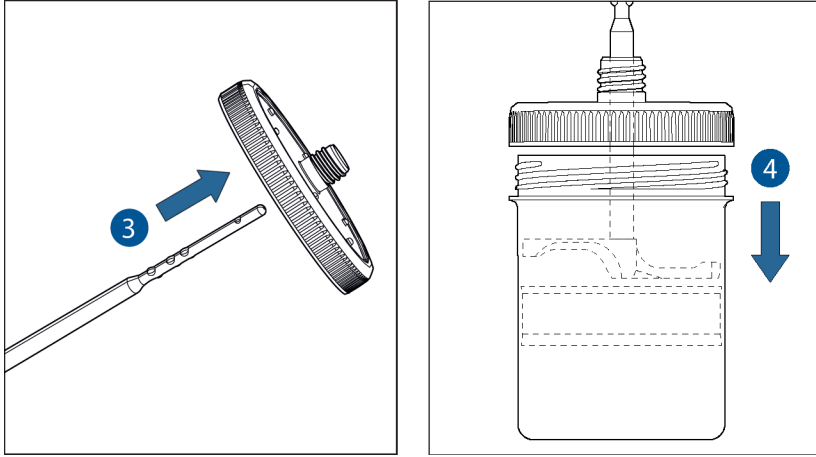

Fig. 9: Insert mixing blade and press down jar base



NOTICE

Press down the base of the jar before weighing in ingredients or filling as far as the stop. Otherwise, you cannot necessarily place elements (especially particularly light components) in the jar.

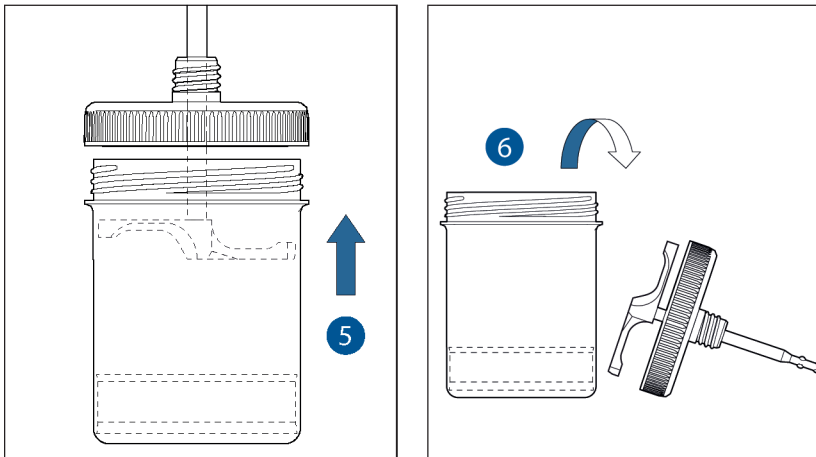

Fig. 10: Remove jar lid with mixing blade and set down

You can now weigh in the recipe components in the jar.

6.3 Preparation of mixing process

Proceed as follows after weighing in the recipe components:

1. Gently screw the mixing blade and the jar lid on the jar housing.
2. Push the jar base upwards using your thumbs so that air escapes between the jar lid and jar housing.

With this air reduction, any overpressure in the jar is released and the escaping of the ointment at the sealing areas of the jar during the mixing process is prevented. The mixing result is also optimized by avoiding air pockets.



NOTICE

If the air is not released from the jar, an air column forms on the inside when mixing the ointment, meaning the mixing blade cannot clean itself. In this case, unmixed components may remain adhered to the mixing blade.

3. Firmly screw down the mixing unit.



NOTICE

Screw the jar lid onto the jar. If the jar lid is screwed on at an angle, the mixing blade tilts upon automatic entry into the bayonet guide.



NOTICE

When incorporating large powder amounts, it is recommended to repeat the air release after approximately 15 seconds of mixing.

6.4 Switching on and selecting the operating mode

Proceed as follows:

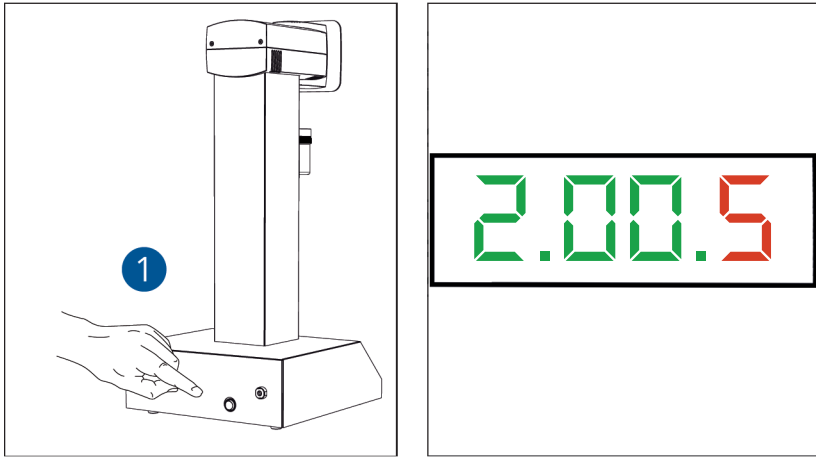

Fig. 11: Switch on power switch; display with standard settings



NOTICE

The standard settings are displayed after switching on the SAMIX® ES500. A mixing time of "2 minutes" and speed setting "5" are set by default.

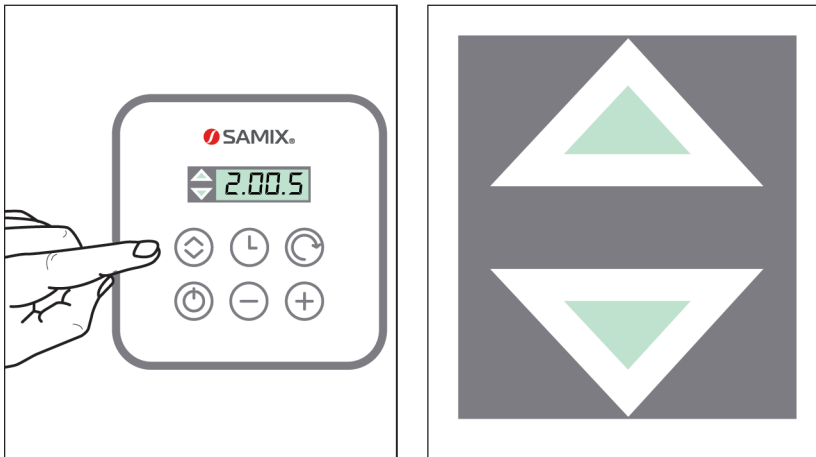

Fig. 12: Select the operating mode using the "AUTO/MANUAL" button



NOTICE

The current operating mode is shown on the display by the illumination of the triangle above AUTO (automatic lifting) or below MANUAL (manual lifting).



NOTICE

When the operating mode is changed, the oscillation arm of the SAMIX® ES500 is automatically moved to the corresponding start position.

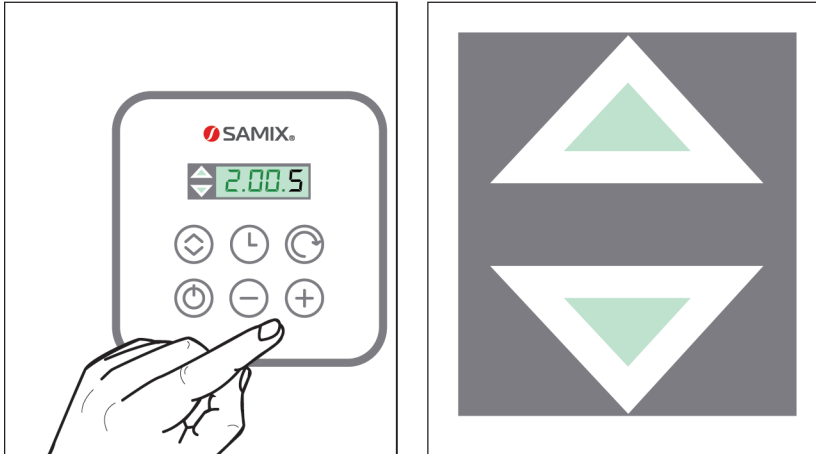

Fig. 13: Specify the mixing time using the "-" and "+" buttons

The mixing time can be set in a range between 0 seconds and 9 minutes and 55 seconds.

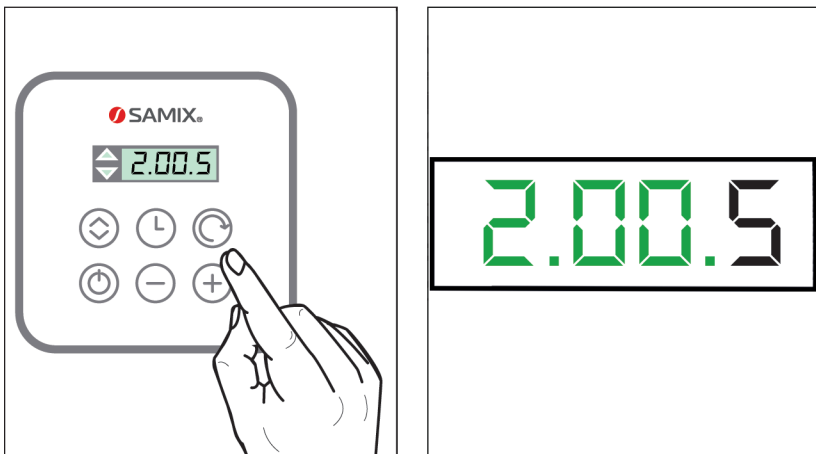

Fig. 14: Switch to the mode to select the speed setting using the "Speed" button

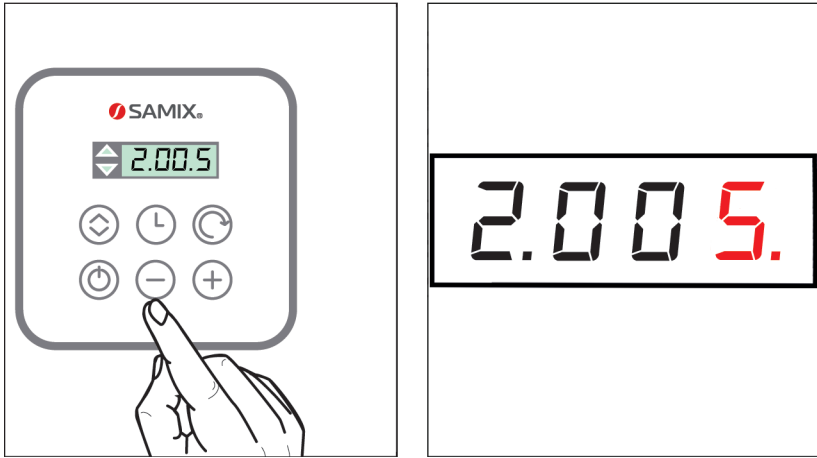

Fig. 15: Specify the speed setting using the "-" and "+" buttons

The speeds (rpm) for the speed settings are listed in the following table:

Speed setting	Speed	Speed setting	Speed
0	650 rpm	5	1450 rpm
1	810 rpm	6	1610 rpm
2	970 rpm	7	1770 rpm
3	1130 rpm	8	1930 rpm
4	1290 rpm	9	2100 rpm

Tab. 4: Value table of speed settings

i NOTICE

You can switch to the mode to select the mixing time or the speed by pressing the "Time" or "Speed" button. The value which can currently be changed using the "-" and "+" buttons is displayed with a point in the respective number field.

6.5 Mixing process in AUTO operating mode

6.5.1 Starting the mixing process

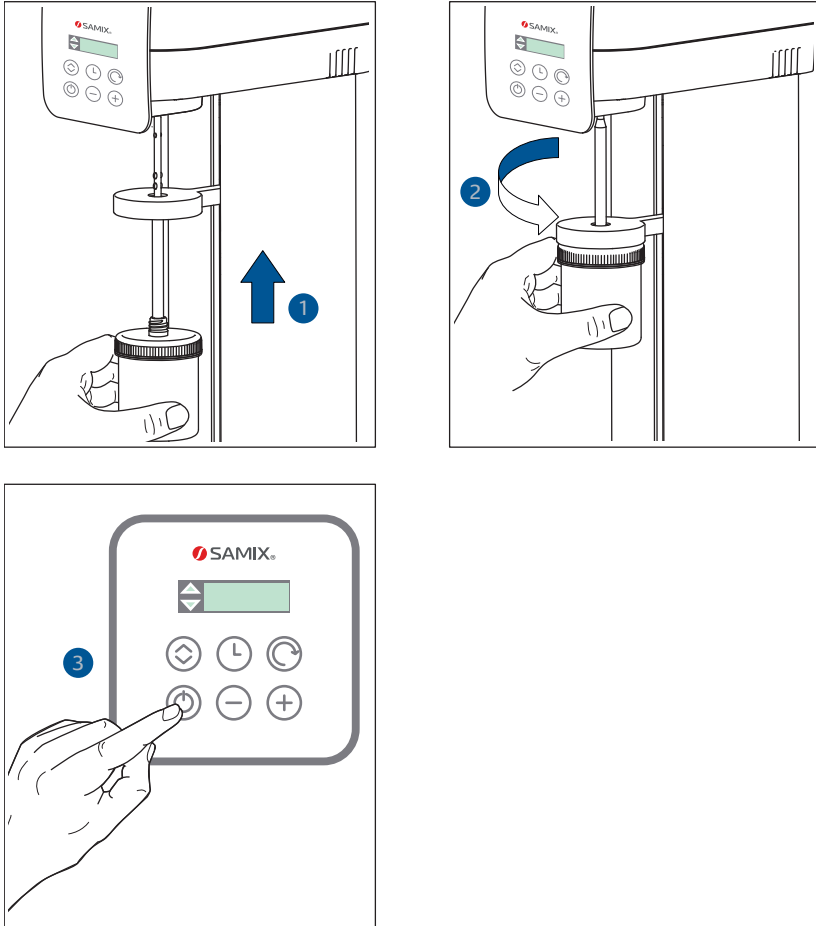

Fig. 16: Mount the mixing unit at the oscillation arm and start the mixing using "Start/Stop"

The oscillation arm is automatically moved up and the bayonet mount grips the mixing blade. The mixing process starts and the recipe is automatically mixed for the defined period at the set speed and with even upward and downward movements.



NOTICE

If the mixing unit was not secured at the oscillation arm or was secured incorrectly, the SAMIX® ES500 is switched off.



NOTICE

The mixing time and speed can also be changed during the mixing process using the "-" and "+" buttons.



NOTICE

You can cancel the mixing process by pressing the "Start/Stop" button.

After the mixing time has lapsed, the SAMIX® ES500 automatically performs the so-called "free spin motion". Here the oscillation arm moves down and the mixing engine accelerates to speed setting 9. The mixing blade is cleared of ointment by the high-speed rotating movements.



NOTICE

"FSL" is shown on the display during the free spin motion.

The mixing process is completed after the free spin motion.

The total mixing time including the reset times is shown on the display.

You can now remove the mixing unit (section „6.5.2 Switching off and removing the mixing unit“).

6.5.2 Switching off and removing the mixing unit



ATTENTION

Risk of material damage!

Remove the mixing unit downwards from the oscillation arm in order to avoid damage to the oscillation arm or the mixing shaft.



NOTICE

After the mixing unit has been removed from the oscillation arm, it is useful to turn the mixing unit in an anticlockwise direction in order to remove the mixing blade from the bayonet mount.

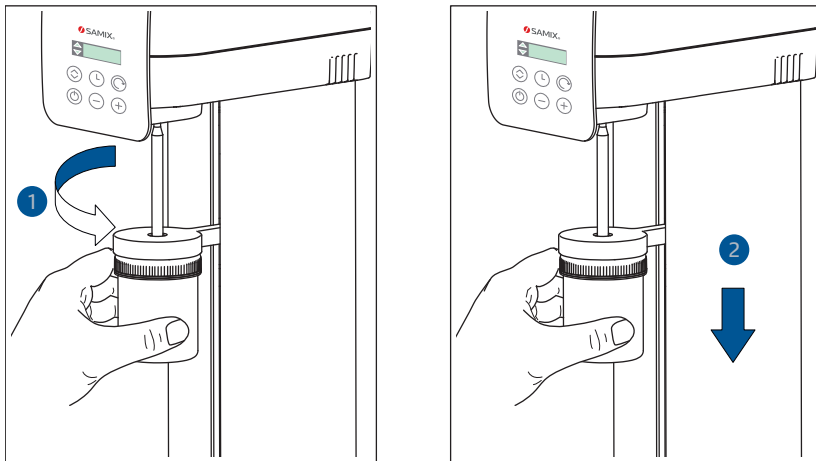

Fig. 17: Unscrew the mixing unit from the oscillation arm and remove mixing unit

If necessary, switch off the power switch.



NOTICE

In the event of a prolonged period of non-usage, it is recommended to switch off the SAMIX® ES500.

6.6 Mixing process in MANUAL operating mode

MANUAL operating mode is only intended for jars with a nominal volume up to 200 ml. Use AUTO operating mode for larger jars.

6.6.1 Starting the mixing process



CAUTION

Risk of injury from unsteady holding of mixing unit during the mixing process!
Firmly hold the mixing unit with at least one hand during the mixing process.



ATTENTION

Risk of material damage!

In order to avoid a destruction of the hollow shaft, the SAMIX® mixing blade shaft must be inserted fully in the device. The bayonet noses can no longer be visible, only the gold-colored coating.

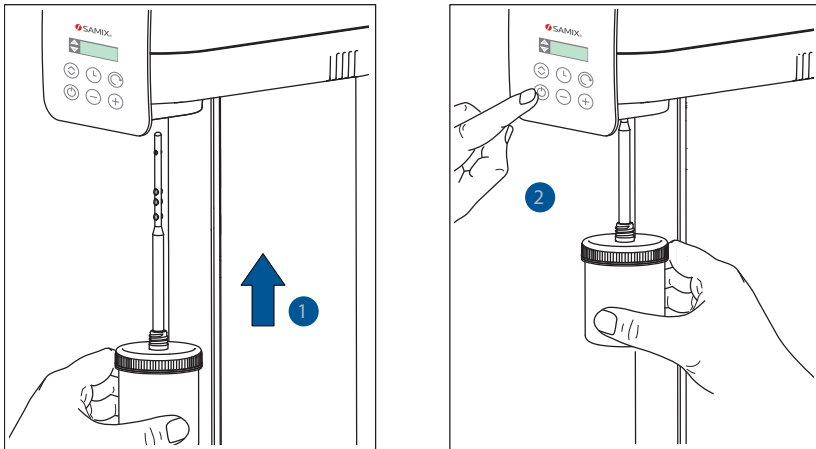

Fig. 18: Mount the mixing unit and start the mixing process using "Start/Stop"

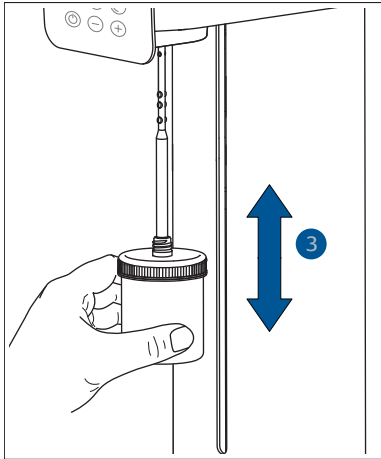

Fig. 19: Guide the jar up and down



NOTICE

The bayonet mount takes effect by pressing the "Start/Stop" button. This status remains until the end of the mixing process.

You can cancel the mixing process by pressing the "Start/Stop" button again.



NOTICE

The mixing time and speed can also be changed during the mixing process using the "-" and "+" buttons.

The recipe is automatically mixed for the defined period at the set speed.



NOTICE

In order to achieve an optimal mixing result, you should perform at least 50 strokes. The required mixing time increases with the size of the jar.



NOTICE

If you want to clean the mixing blade using a manual free spin motion in MANUAL operating mode, you have to press the "Start/Stop" button before the mixing time lapses.

The mixing process is interrupted and "FSLA" is shown on the display.

The total mixing time including the reset times is shown on the display after the manual mixing process. You can now

- perform a manual free spin motion („6.6.2 Manual free spin motion“),
- remove the mixing unit without a free spin motion („6.6.3 Switching off and removing the mixing unit“).

6.6.2 Manual free spin motion

During the so-called "free spin motion", the mixing blade is cleaned of ointment to the greatest possible extent by high-speed rotation. Proceed as follows for the manual free spin motion:

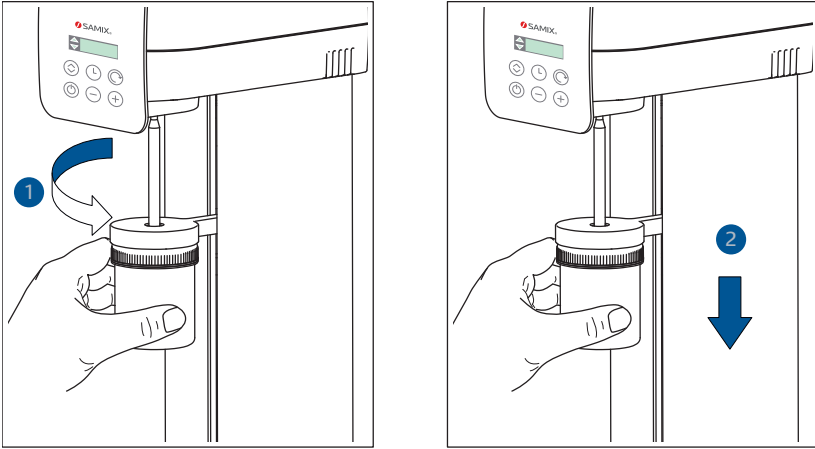

Fig. 20: Remove mixing unit

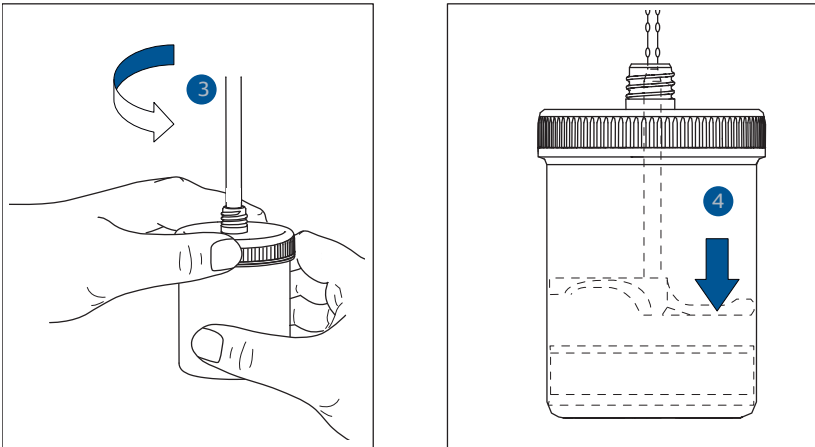

Fig. 21: Open the jar lid slightly and push down the base with mixing blade

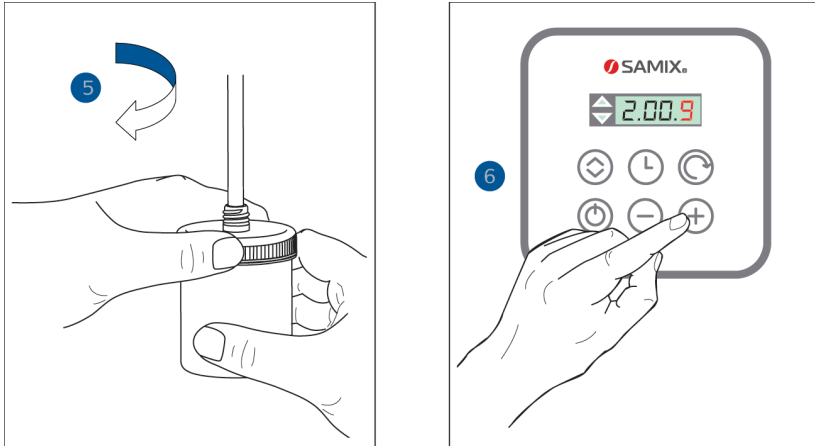

Fig. 22: Close the jar lid tightly and select a high speed using the "+" button



CAUTION

Risk of injury from unsteady holding of mixing unit during the free spin motion!
Firmly hold the mixing unit with at least one hand during the free spin motion.



ATTENTION

Risk of material damage!

In order to avoid a destruction of the hollow shaft, the SAMIX® mixing blade shaft must be inserted fully in the device. The bayonet noses can no longer be visible, only the gold-colored coating.



NOTICE

If the display shows "FSLA", the free spin motion can be started by pressing the "Start/Stop" button.

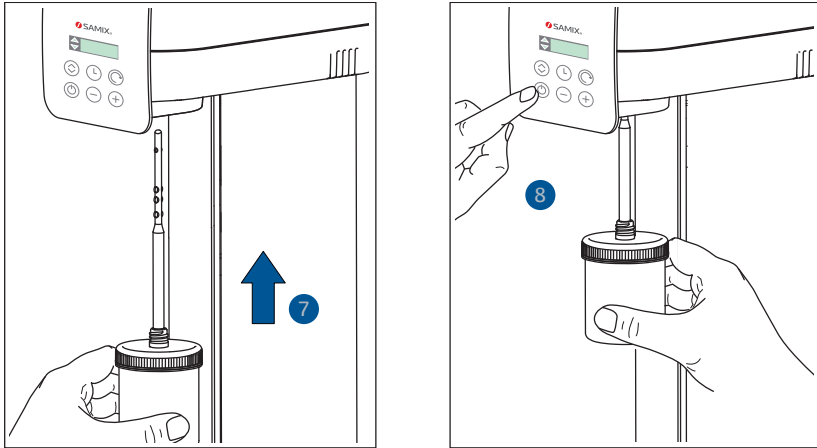

Fig. 23: Mount the mixing unit, hold tight, and start the free spin motion using "Start/Stop"



NOTICE

Ensure that the mixing blade is located close to the lid.



NOTICE

The bayonet mount takes effect by pressing the "Start/Stop" button. This status remains until the end of the mixing process.

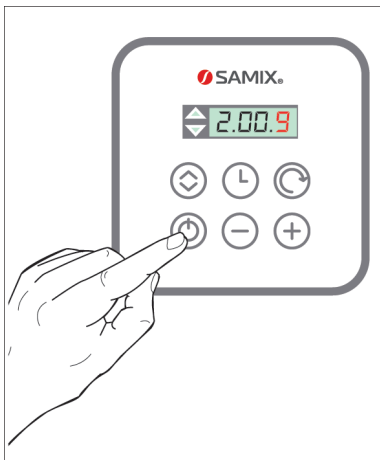

Fig. 24: After a few seconds end the free spin motion by pressing the "Start/Stop"button

You can now remove the mixing unit („6.6.3 Switching off and removing the mixing unit“).

6.6.3 Switching off and removing the mixing unit

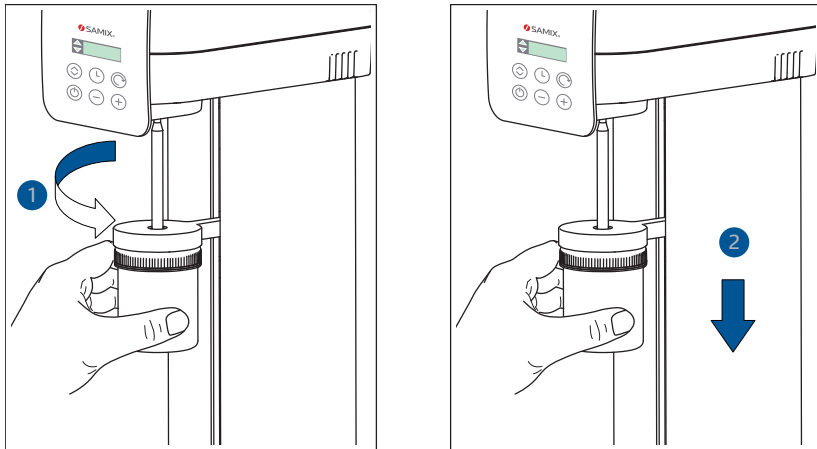

Fig. 25: Remove mixing unit

If necessary, switch off the power switch.



NOTICE

In the event of a prolonged period of non-usage, it is recommended to switch off the SAMIX® ES500.

6.7 Final operations

Proceed as follows after the removal of the mixing unit:

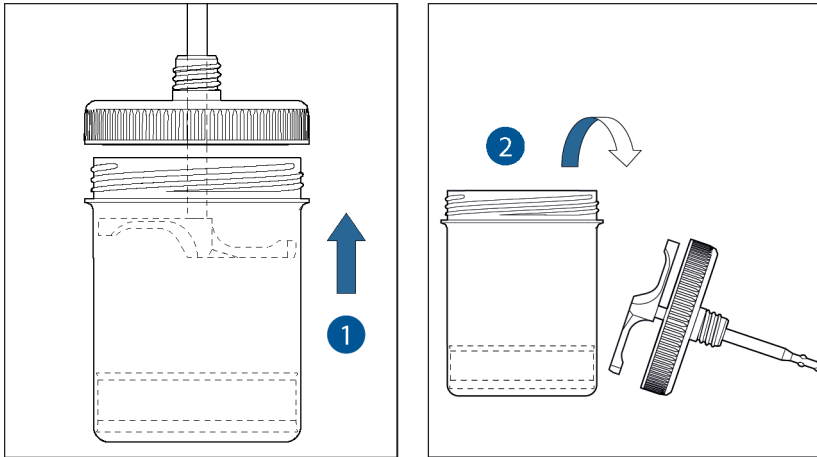

Fig. 26: Unscrew jar lid and set down mixing blade with jar lid

Check the surface of the ointment.

If the surface of the ointment looks smooth and consistent, it has been proved in practice that the consistency of the ointment was also achieved in the inside of the jar. In this case continue as described in Fig. 27.

If the surface of the ointment is not consistent, repeat the steps from the aforementioned sections.

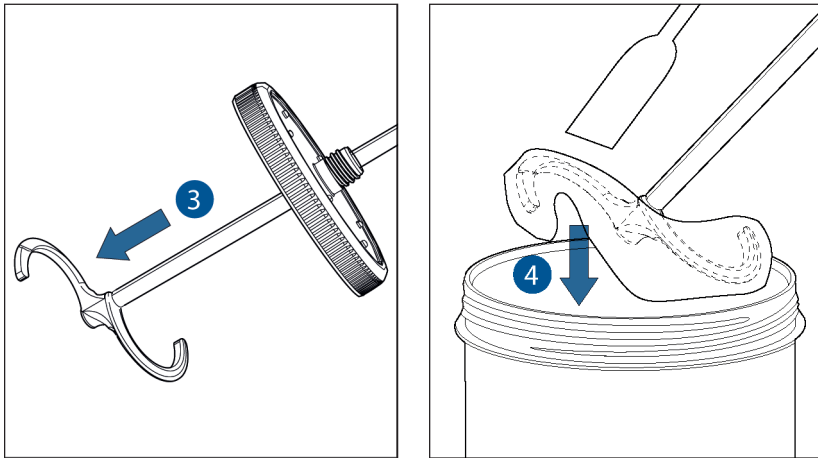

Fig. 27: Push the mixing blade from the jar lid and scrape off ointment using a spatula

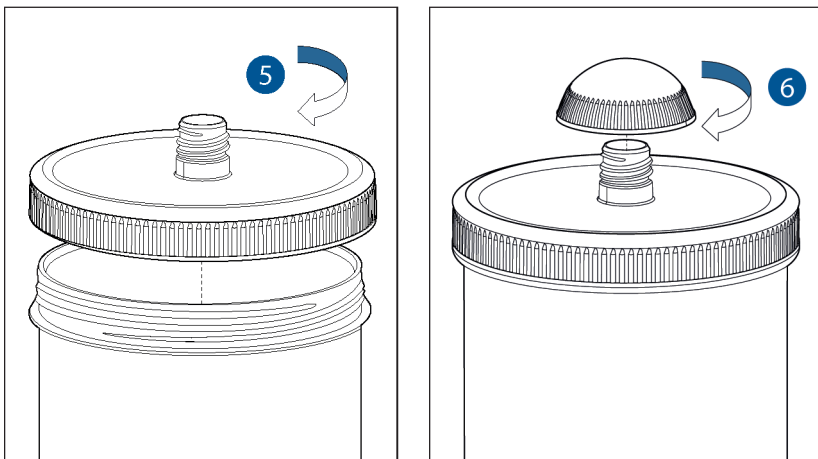

Fig. 28: Screw back on the jar lid tightly and the jar cap gently



NOTICE

You can also have the jar lid with a SAMIX® vario nozzle.

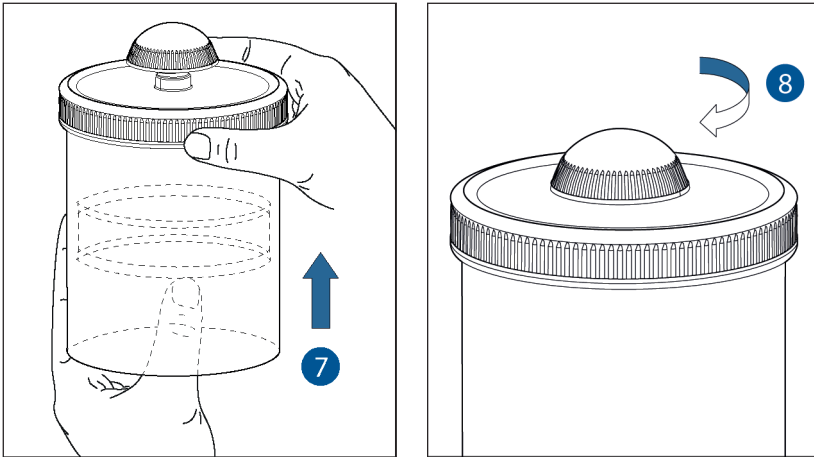

Fig. 29: Reduce air and firmly screw on jar cap



NOTICE

The air reduction before the discharge of the jar serves to remove any air-filled areas arising during the mixing process. If no air reduction is performed, during the first withdrawal the operator first pushes the air and then the ointment from the jar opening in a gushing movement.

Stick the label on the sealed jar and give the jar to the operator.



NOTICE

It is recommended to document the stroke and mixing parameters, as well as the result of the final check.

7 Maintenance, repair and cleaning

7.1 Service and warranties in Germany

Regardless of the obligations of the seller vis-a-vis the purchaser, the manufacturer assumes a warranty in accordance with the specifications in the enclosed documentation.

The Technical Service Department for SAMIX® mixers can be reached at:

SAMIX GmbH
Am Köhlersgehäu 50
98544 Zella Mehlis
Germany

www.samix.com
info@samix.com

Tel.: +49 3682 455 0
Fax: +49 3682 455 200



NOTICE

Repairs carried out under warranty are only performed by SAMIX GmbH.



NOTICE

In the case of faults needing repair, send the entire SAMIX® ES500 device to SAMIX GmbH. Use the material of the original packaging or request packaging material from SAMIX GmbH to send in the device.

In addition, observe the following information for services:

- A quote can be obtained for service repairs.
- For SAMIX® devices sent in, a return deadline of 6 working days following receipt or confirmation of the quote is promised.
- Mixing blades and jars, as well as other SAMIX® products, are not covered under the warranty.
- The warranty claim becomes null and void if unauthorized operations or procedures have been performed on the device. Damage arising from improper use or as a result of force majeure or other external influences is not covered under the warranty.
- The parts replaced during maintenance and repair become the property of SAMIX GmbH.
- Claims beyond the free troubleshooting, for e.g. damages, cannot be asserted within the framework of the warranty.
- A warranty claim only exists if proof of purchase can be demonstrated.



NOTICE

Please note the information and details in the enclosed documentation.

7.2 Maintenance



NOTICE

The SAMIX® ES500 is serviced solely by the personnel of SAMIX GmbH.

The inspection and maintenance work to be performed for documentation within the framework of a QM system can be obtained from customer service upon request.



NOTICE

When utilizing services, send the entire SAMIX® ES500 device to SAMIX GmbH.

Use the material of the original packaging or request packaging material from SAMIX GmbH for sending in the device.

Observe the following information:

- Services are also invoiced within the warranty period for costs and wear parts.
- Upon request, a replacement device is provided for the duration of the service work in return for a one-off rental charge.



NOTICE

Please note the information in the enclosed documentation for warranty cases.

7.3 Cleaning



WARNING

Electrical hazard from direct contact with live parts!

Always remove the connector from the socket before cleaning the SAMIX® ES500.



ATTENTION

Risk of material damage!

Do not open the housing of the SAMIX® ES500 without authorization.

Do not use any aggressive cleaning substances or abrasive cleaners for cleaning.

Ensure that no liquid enters the device. If liquid ends up in the inside of the SAMIX® ES500, disconnect the device from the power supply and inform customer service.

Proceed as follows for daily cleaning of the device:

1. Disconnect the connector from the socket.
2. Wipe the surfaces of the device using a damp cloth (wet with mild soapy water).
3. Dry the surfaces of the device using a soft, dry cloth.



NOTICE

To disinfect, you can spray the display of the SAMIX® ES500 using a suitable cleaning agent (for e.g. containing 70% isopropyl alcohol) and wipe.

8 Fault causes/troubleshooting

8.1 Instructions in the event of faults

Fault	Troubleshooting
The SAMIX® ES500 cannot be switched on.	Check whether there is supply voltage and the connector is correctly connected to the socket.
The SAMIX® ES500 switched off due to an overload.	Switch off the power switch. Observe a cooling period of 30 minutes.

Tab. 5: Faults and troubleshooting



NOTICE

In the event of irregularities, a fault message is shown on the display. Information on the cause of the fault and troubleshooting can be found in section „8.2 Fault messages“.



NOTICE

An incorrect assignment of the mixing blades to the jars can trigger fault messages.

After the device is switched off and the operating fault has been eliminated, the SAMIX® ES500 works again normally.

Following troubleshooting perform a function check in accordance with the details under "Function check or initial operation" in the enclosed document "Installation Qualification (IQ)".

In the case of serious faults, note the device type and contact the manufacturer.



NOTICE

In the case of faults needing repair, send the entire SAMIX® ES500 device to SAMIX GmbH. Use the material of the original packaging or request packaging material from SAMIX GmbH when sending in the device.



NOTICE

After an operation period of approximately 500 hours, the contact carbon brushes of the SAMIX® ES500 may be worn. The contact carbon brushes are replaced during the regular maintenance work performed by SAMIX GmbH.

The inspection and maintenance work to be performed for documentation within the framework of a QM system can be obtained from customer service upon request.

8.2 Fault messages

Fault display	Possible cause of fault	Troubleshooting
FE 0	The device was switched off and on again during an operation or a temporary power failure.	Press the "Start/Stop" button. The oscillation arm moves to the next end position.
FE 1	The device was switched on while a mixing unit is engaged or a changeover of operating modes was effected while a mixing unit was engaged.	Remove the mixing unit and press the "Start/Stop" button. The oscillation arm moves to the previously desired position.
FE 2	The oscillation arm does not move or only moves very slowly.	Press the "Start/Stop" button. Fault message FE 0 is displayed.
FE 8	No mixing unit is engaged in MANUAL operating mode.	Press the "Start/Stop" button, engage mixing unit. Restart.
FE 9	In AUTO operating mode no mixing unit is secured at the oscillation arm.	The oscillation arm automatically moves back to the start position.
	In AUTO operating mode no mixing unit is engaged or disengaged.	Remove the mixing unit and press the "Start/Stop" button.
FE A	The engine is temporarily overloaded.	Press the "Start/Stop" button. If necessary, switch off the device and allow the device to cool down for 30 minutes.

Tab. 6: Fault messages

8.3 Possible fault sources to avoid

Potential faults	Possible consequences	Troubleshooting
The incorrect mixing blade is used.	The mixing blade shaft is too long and the jar cannot be screwed into the oscillation arm.	Use a mixing blade with a suitable shaft length (see section „3.2.3 Assignment of mixing blades to the jars“).
The incorrect mixing blade is used.	The mixing blade shaft cannot be centered in the holder after performing a full stroke.	Use a mixing blade with a suitable shaft length (see section „3.2.3 Assignment of mixing blades to the jars“).
Defective (for e.g. bent) mixing blades or other mixing blades than those supplied are used.	The mixing blade does not engage or engages only partly in the bayonet mount.	Only use intact SAMIX® mixing blades with appropriate shaft length (see section „3.2.3 Assignment of mixing blades to the jars“).
The mixing blade is operated without a jar with the device.	Risk of injury upon contact with the rotating mixing blade.	Only use mixing blades with the SAMIX® ES500 in jars which have been firmly screwed in.
Jars with a nominal volume from 1000 ml are used.	The device switches off as a result of an overload.	Only use jars with a nominal volume up to 500 ml.
When inserting the mixing blade in the jar lid, the sealing lip of the jar lid opening breaks with the noses of the mixing blade shaft.	Ointment elements (mainly liquid) may draw up at the shaft of the mixing blade during the mixing process.	When inserting the mixing blade in the jar lid, do not break the sealing lip of the jar lid opening with the noses of the mixing blade shaft. Perform air reduction before the mixing process.
The base of the jar is not pushed down as far as the stop before weighing in the ingredients.	All recipe components cannot be housed in the jar, although the filling volume is on average 40% larger than the nominal volume.	Press down the base of the jar fully before weighing in the ingredients. Use the next biggest jar.
For the manufacture of low-viscose preparations, the sealing lips of the jar base are not wet with an ointment base.	Mixed material may emerge at the jar base during preparation.	Wet the sealing lips of the base with ointment base to support the sealing effect.
The air is not removed from the jar before the mixing of semi-solid preparations.	An air column forms on the inside of the jar when mixing the ointment, meaning the mixing blade cannot clean itself. Unmixed elements may remain stuck on the mixing blade.	Perform air reduction before the mixing process.
The air is not removed from the jar before the mixing of liquid preparations.	During mixing overpressure arises which cannot be reduced by pushing down the movable base. As a result, ointment can draw up on the shaft of the mixing blade during the mixing process.	Perform air reduction before the mixing process.

Potential faults	Possible consequences	Troubleshooting
The jar lid is screwed onto the jar at an angle.	The mixing blade tilts upon automatic entry into the bayonet mount.	Screw the lid onto the jar properly and tightly.
The oscillation arm is pulled too far from the defined starting position by hand.	The mixing blade shaft is not centered in the holder after performing a full stroke.	Take hold of the mixing blade shaft at the taper and manually guide it into the holder.
The mixing unit is not held firmly with at least one hand during the entire mixing period in the case of a manual lifting process.	Risk of injury as a result of unstable holding of the mixing unit during the entire mixing process in the case of manual lifting process.	Firmly hold the mixing unit with at least one hand during the entire mixing period in the case of manual lifting process.
After heavy loads, the device is not switched off for cooling.	In the event of an overload, a thermal safety element shuts down the mixing function of the device.	Switch off the power switch or disconnect the connector. Switch off the device and allow to cool for 30 minutes.
No air reduction is performed before handover of the jar to the operator.	The air reduction serves for pushing out any air-filled spaces arising during the mixing process. During the first withdrawal the operator first pushes the air and then the ointment from the jar opening in a gushing movement.	Perform air reduction before the handover of the jar to the operator. If necessary, use a vario nozzle or an applicator.

Tab. 7: Possible fault sources to avoid

9 Waste disposal



NOTICE

SAMIX® devices cannot be disposed of with general household waste. At the end of their service life, send SAMIX® devices to the available return and collection systems.

Contact

SAMIX GmbH
Am Köhlersgehäu 50
98544 Zella Mehlis
Germany

www.samix.com
info@samix.com

Tel.: +49 3682 455 0
Fax: +49 3682 455 200

